

SCATTERING OF INTERNAL WAVES IN A STRATIFIED FLUID BY THE EDGE OF AN INERTIAL SURFACE

PRITY DOLAI¹ AND B.N. MANDAL²

(Received 2 March 2006)

Abstract. The problem of internal wave scattering by the edge of a semi-infinite inertial surface partly covering an exponentially stratified incompressible liquid of infinite depth is investigated in this paper. Assuming linear theory the problem is formulated in terms of a function related to the stream function describing the motion in the liquid. The related boundary value problem involves the Klein-Gordon equation which is a PDE of hyperbolic type. The BVP is solved with the aid of Wiener Hopf technique applied to a slightly more general problem and passing on to the limit in a manner so as to obtain the solution of the original problem. The scattered field is obtained in terms of integrals which are evaluated asymptotically in different regions for large distance from the edge. The asymptotic form of the wave field is plotted graphically for various cases to visualize the nature of the scattered wave field.

1. Introduction. In the mathematical modelling of wave phenomena in a deep liquid, a part of which is covered by an inertial surface composed of a thin but uniform distribution of non-interacting floating particles (e.g., broken ice, floating mat on water) while the remaining part is free, the surface boundary condition becomes discontinuous in the sense that there is one condition at the inertial surface and another condition at the free surface. For a homogeneous liquid (e.g. water), Peters (1950), Weitz and Keller (1950) developed mathematical models to investigate scattering of surface waves travelling from the free surface region and normally or obliquely incident on the line separating the free surface and the inertial surface. Gabov et. al. (1989) generalised these problems for two immiscible homogeneous liquids for which half the interface is covered by an inertial surface and the other half is a free separating boundary of the two liquids. Recently Kanoria et al. (1999) investigated two mixed boundary value problems involving surface water wave in deep water (or interface wave in two superposed homogeneous liquids) arising due to one or two discontinuities in the surface (or interface) boundary conditions. The governing partial differential equation in these problems is the Laplace equation which, together with the boundary conditions, is generalised to the Helmholtz equation alongwith slightly different boundary conditions by introducing a complex parameter to facilitate the use of Wiener-Hopf technique in the mathematical analysis. Ultimately this parameter is made to tend to zero to obtain the solutions of the original problems.

Instead of a homogeneous liquid, if we have a stratified liquid in which the density varies exponentially along the vertical direction, then the governing PDE describing the propagation of steady state internal waves becomes the Klein-Gordon equation (Gabov and Sveshnikov, 1982 and Varlamov, 1983, 1985). Let the stratified liquid occupy the region $y \leq 0$ when at rest, wherein the y -axis is chosen vertically upwards so that the upper surface of the liquid

at the rest position coincides with the plane $y = 0$. The liquid is exponentially stratified along the y -direction so that its density in the unperturbed state is assumed to be of the form $\rho_0(0) \exp(-2\beta y)$ ($\beta > 0$) where $\rho_0(0)$ is the density at the top of the liquid.

Writing the stream function

$$\psi(x, y, t) = u(x, y, t) \exp(\beta y), \quad (1.1)$$

it can be shown that u satisfies the PDE

$$\frac{\partial^2}{\partial t^2}(\nabla^2 u - \beta^2 u) + w_0^2 \frac{\partial^2 u}{\partial x^2} = 0, \quad (1.2)$$

where ∇^2 denotes the two-dimensional Laplacian, and $w_0 = (2\beta g)^{1/2}$ is the so-called Brunt Vaisala frequency.

For plane wave solutions, the time dependence can be chosen to be harmonic so that $u(x, y, t)$ can be written as $\text{Re}\{u(x, y) \exp(-i\omega t)\}$ where $u(x, y)$ is now complex valued, ω is the circular frequency, and the same notation u is used without any confusion. If $\exp(ik_1 x + ik_2 y - i\omega t)$ represents a plane wave solution of the PDE (1.2), then the dispersion relation is

$$\omega^2 = \frac{w_0^2 k_1^2}{k_1^2 + k_2^2 + \beta^2}. \quad (1.3)$$

The group velocity $\mathbf{v}_g = \left(\frac{\partial \omega}{\partial k_1}, \frac{\partial \omega}{\partial k_2} \right)$ is then obtained as

$$\mathbf{v}_g = \frac{w_0 \text{sgn}(k_1)}{(k_1^2 + k_2^2 + \beta^2)^{3/2}} (k_2^2 + \beta^2, -k_1 k_2). \quad (1.4)$$

Thus the directions of the wave vector $\mathbf{k} = (k_1, k_2)$ and the group velocity vector \mathbf{v}_g do not coincide unless $k_2 = 0$. Since the direction of \mathbf{v}_g determines the direction of energy flow in the wave, the direction of wave propagation is to be taken as the direction of \mathbf{v}_g rather than that of \mathbf{k} . Also, the dispersion relation (1.3) ensures that plane wave type solutions are possible only when $\omega < w_0$, and this will be assumed all throughout here.

The complex valued function $u(x, y)$, which is related to the stream function, now satisfies the Klein-Gordon equation

$$\frac{\partial^2 u}{\partial y^2} - \beta^2 u = \frac{1}{a^2} \frac{\partial^2 u}{\partial x^2}, \quad (1.5)$$

where

$$\frac{1}{a^2} = \frac{w_0^2}{\omega^2} - 1. \quad (1.6)$$

Thus the governing differential equation (1.5) here is a PDE of hyperbolic type in contrast to PDEs of elliptic type encountered in the classical diffraction theory.

Gabov (1982), Gabov and Sveshnikov (1982) investigated scattering of two-dimensional steady-state internal waves in an exponentially stratified incompressible liquid by the boundary

of a solid half plane. This models interaction of waves with a rigid ice field covering half the surface of an infinitely deep ocean whose density varies along the vertical direction in an exponential manner. They used the Wiener-Hopf technique in the mathematical analysis. Several researchers, mostly Russians, soon afterwards investigated a number of variations of these problems by using the same technique. For example, Varlamov (1983, 1985) investigated internal wave scattering by a semi-infinite horizontal wall present inside the liquid and by a semi-infinite elastic half plate present on the surface of the liquid.

In the present paper, the problem of internal wave scattering by a semi-infinite inertial surface partly covering an exponentially stratified liquid is investigated. This may be regarded as a generation of the classical scattering problem considered by Peters (1950) for surface water waves in the presence of an inertial surface (e.g., broken ice, floating mat) to internal wave scattering by an inertial surface covering an exponentially stratified liquid. Assuming linear theory and under Boussinesq approximation with constant Brunt Vaisala frequency, the problem is formulated as a boundary value problem involving the Klein-Gordon equation with discontinuous surface boundary conditions. The problem is handled for its solution with the aid of Wiener-Hopf technique after introducing a small positive imaginary part in the parameter a defined by the relation (1.6), as well as by slightly generalising the surface boundary conditions, the edge conditions and the infinity requirements, and ultimately passing on to the limit as this small imaginary part of a tends to zero. The diffracted field is obtained in terms of integrals which are evaluated asymptotically for large distances from the edge of the inertial surface by the method of steepest descent and interpreted physically. The asymptotic form of the wave field is plotted graphically for various cases to visualize the nature of the scattered wave field.

2. Formulation of the Problem. Let an incompressible inviscid exponentially stratified liquid occupy the half space $y \leq 0$ when at rest, and the half-plane $y = 0, x < 0$ be the rest position of the free surface while the remaining half plane $y = 0, x > 0$ be the rest position of the inertial surface with area density σ .

The linearised free surface condition for the complex valued function $u(x, y)$ is

$$\frac{g}{w^2} \frac{\partial^2 u}{\partial x^2} + \frac{\partial u}{\partial y} + \beta u = 0 \text{ on } y = 0, x < 0. \quad (2.1)$$

while the linearised condition at the inertial surface can be obtained as (cf. Peters (1950))

$$\frac{c}{\rho_0 w^2} \frac{\partial^2 u}{\partial x^2} + \frac{\partial u}{\partial y} + \beta u = 0 \text{ on } y = 0, x > 0, \quad (2.2)$$

where $\rho_0 \equiv \rho_0(0)$ and

$$c = g\rho_0 - \sigma w^2. \quad (2.3)$$

We can assume that the constant c is a positive quantity so long as $w < w_0$. This is due to the fact that under actual conditions concerning a stratified ocean, $w_0^2 \approx 10^{-4} \text{ Hz}^2$ and when the ocean is covered with ice which is modelled as a thin elastic plate of surface density σ , $\frac{g\rho_0}{\sigma} \approx 10 \text{ Hz}^2$ (cf. Varlamov 1985). In the present case when the ocean is covered with broken

ice (inertial surface) we can assume that $\frac{g\rho_0}{\sigma}$ is also in the same range. Thus $w_0^2 < \frac{g\rho_0}{\sigma}$, and hence $c > 0$ since $w < w_0$ has already been assumed.

Let from the region $x < 0, y < 0$, a plane wave field represented by

$$\phi_0(x, y) = \exp(-iby + ikx), \quad (2.4)$$

where

$$k^2 = a^2(b^2 + \beta^2), \quad (2.5)$$

and b and k are taken to be positive, propagate from infinity and be incident on the edge of the inertial surface separating the free surface. The group velocity, given by the relation (1.4), for this wave is directed towards the edge of the inertial surface while the phase velocity is directed away from it. The total wave field u can be represented in the form

$$u(x, y) = \phi_0(x, y) + \phi_1(x, y) + \phi(x, y), \quad (2.6)$$

where

$$\phi_1(x, y) = R \exp(iby + ikx), \quad (2.7)$$

with

$$R = \frac{ib - \beta + \frac{gk^2}{w^2}}{ib + \beta - \frac{gk^2}{w^2}}, \quad (2.8)$$

so that it represents the wave reflected from the free surface, and $\phi(x, y)$ is the diffracted field. $\phi(x, y)$ satisfies the boundary value problem described by the Klein-Gorden equation

$$\frac{\partial^2 \phi}{\partial y^2} - \beta^2 \phi = \frac{1}{a^2} \frac{\partial^2 \phi}{\partial x^2}, \quad y < 0, \quad (2.9)$$

and the boundary conditions

$$\frac{g}{w^2} \frac{\partial^2 \phi}{\partial x^2} + \frac{\partial \phi}{\partial y} + \beta \phi = 0 \quad \text{on } y = 0, x < 0, \quad (2.10)$$

$$\frac{c}{\rho_0 w^2} \frac{\partial^2 \phi}{\partial x^2} + \frac{\partial \phi}{\partial y} + \beta \phi = A \exp(ikx) \quad \text{on } y = 0, x > 0, \quad (2.11)$$

where

$$A = -\frac{2ibk^2\sigma}{\rho_0 \left(ib + \beta - \frac{gk^2}{w^2} \right)}. \quad (2.12)$$

To apply the Wiener-Hopf technique for finding the solution for ϕ , we assume that the constant a occurring in the PDE (2.9) has a small positive imaginary part ε so that the constant k defined by (2.5) has a positive imaginary part $\delta(\varepsilon) = (b^2 + \beta^2)^{1/2} \varepsilon$ which tends to zero as $\varepsilon \rightarrow 0+$.

Also ϕ satisfies the edge conditions

$$|\phi| = O(1), |\nabla\phi| = O(1), |\nabla^2\phi| = O(1) \text{ as } r = (x^2 + y^2)^{1/2} \rightarrow 0, \quad (2.13)$$

and the condition at infinity, as given by

$$|\phi| + |\nabla\phi| + \left| \frac{\partial^2\phi}{\partial x^2} \right| \leq \text{const. exp}(-\chi(\varepsilon)r) \text{ as } r = (x^2 + y^2)^{1/2} \rightarrow \infty, \quad (2.14)$$

where $0 < \chi(\varepsilon) \leq \min(\varepsilon\beta, \delta(\varepsilon)) = \varepsilon\beta$ so that $\chi(\varepsilon) \rightarrow 0$ as $\varepsilon \rightarrow 0+$.

The condition (2.13) follow from the fact that the energy flux through an arbitrary closed surface encompassing the edge of the inertial surface is equal to zero while the condition (2.14) follows from the requirement that the diffracted waves carry energy away to infinity.

In the next section, the Wiener-Hopf technique is applied to the generalized BVP satisfying the Klein-Gordon equation (2.9) involving the complex parameter $a = a_1 + i\varepsilon$, the surface boundary conditions (2.10) and (2.11), the edge conditions (2.13) and the infinity requirement (2.14).

3. Solution of the Problem. Let $\Phi(\alpha, y)$ denote the Fourier transform of $\phi(x, y)$ defined by

$$\Phi(\alpha, y) = \int_{-\infty}^{\infty} \phi(x, y) \exp(i\alpha x) dx$$

where $\alpha = \sigma + i\tau$, σ and τ being real. Then

$$\Phi(\alpha, y) = \Phi_-(\alpha, y) + \Phi_+(\alpha, y),$$

where

$$\Phi_+, \Phi_- = \int_0^{\infty}, \int_{-\infty}^0 \phi(x, y) \exp(i\alpha x) dx. \quad (3.1)$$

Now using the condition (2.14) we find that $\Phi_+(\alpha, y)$ is regular in the upper half plane $\tau > -\chi(\varepsilon)$ and $\Phi_-(\alpha, y)$ is regular in the lower half plane $\tau < \chi(\varepsilon)$ of the complex α -plane. The edge conditions (2.13) alongwith the Abelian theorem (cf. Nobel (1958)) ensure that

$$|\Phi_{\pm}(\alpha, 0)| = O(|\alpha|^{-1}) \text{ as } |\alpha| \rightarrow \infty \text{ in } \tau \gtrless \mp\chi(\varepsilon). \quad (3.2)$$

To use the Wiener-Hopf procedure, the boundary conditions (2.10) and (2.11) are rewritten as

$$\frac{g}{w^2} \frac{\partial^2\phi}{\partial x^2} + \frac{\partial\phi}{\partial y} + \beta\phi = \begin{cases} 0 & \text{on } y = 0, x < 0, \\ f(x) & \text{on } y = 0, x > 0, \end{cases} \quad (3.3)$$

$$\text{and } \frac{c}{\rho_0 w^2} \frac{\partial^2\phi}{\partial x^2} + \frac{\partial\phi}{\partial y} + \beta\phi = \begin{cases} g(x) & \text{on } y = 0, x < 0, \\ A \exp(ikx) & \text{on } y = 0, x > 0, \end{cases} \quad (3.4)$$

where $f(x)$ (for $x > 0$) and $g(x)$ (for $x < 0$) are unknown functions. The edge conditions (2.13) ensure that

$$\left. \begin{aligned} |f(x)| &= O(1) \text{ as } x \rightarrow 0+, \\ |g(x)| &= O(1) \text{ as } x \rightarrow 0-. \end{aligned} \right\} \quad (3.5)$$

Now, use of Fourier transform to the PDE (2.9) produces the ODE

$$\frac{d^2\Phi}{dy^2} + \frac{\gamma^2(\alpha)}{a^2}\Phi = 0, \quad y < 0, \quad (3.6)$$

where

$$\gamma^2(\alpha) = \alpha^2 - a^2\beta^2,$$

and we choose that branch of the function $\gamma(\alpha) = (\alpha^2 - a^2\beta^2)^{1/2}$ for which $\gamma(0) = -ia\beta$ in the complex α -plane cut along the line joining the points $-(a_1 + i\varepsilon)\beta$ and $(a_1 + i\varepsilon)\beta$ through infinity.

A solution of the equation (3.6) is

$$\Phi(\alpha, y) = D(\alpha) \exp\left(\frac{i\gamma(\alpha)}{a}y\right), \quad y < 0, \quad (3.7)$$

where $D(\alpha)$ is an arbitrary function of α . Using Fourier transform to the conditions (3.3) and (3.4) we find that $\Phi(\alpha, y)$ must satisfy

$$\left(\beta - \frac{g\alpha^2}{w^2}\right)\Phi(\alpha, 0) + \frac{d\Phi}{dy}(\alpha, 0) = F_+(\alpha), \quad (3.8)$$

and

$$\left(\beta - \frac{c\alpha^2}{\rho_0 w^2}\right)\Phi(\alpha, 0) + \frac{d\Phi}{dy}(\alpha, 0) = -\frac{A}{i(\alpha + k)} + G_-(\alpha), \quad (3.9)$$

where the unknown functions

$$F_+(\alpha) \equiv \int_0^\infty f(x) \exp(i\alpha x) dx \quad \text{and} \quad G_-(\alpha) \equiv \int_{-\infty}^0 g(x) \exp(i\alpha x) dx$$

are regular in the two overlapping half planes $\tau > -\chi(\varepsilon)$ and $\tau < \chi(\varepsilon)$ respectively with $|F_+(\alpha)| = O(|\alpha|^{-1})$ as $|\alpha| \rightarrow \infty$ in $\tau > -\chi(\varepsilon)$ and $|G_-(\alpha)| = O(|\alpha|^{-1})$ as $|\alpha| \rightarrow \infty$ in $\tau < \chi(\varepsilon)$. Using (3.7) in the conditions (3.8) and (3.9) and eliminating $D(\alpha)$, we obtain the following Wiener-Hopf relation, for the determination of the two functions $F_+(\alpha)$ and $G_-(\alpha)$, as given by

$$\frac{F_+(\alpha)}{K(\alpha)} + G_-(\alpha) = \frac{A}{i(\alpha + k)}, \quad (3.10)$$

valid in the strip $\tau_- < \tau < \tau_+$ where τ_\pm are chosen such that $-\chi(\varepsilon) < \tau_- < 0 < \tau_+ < \chi(\varepsilon)$, and

$$K(\alpha) = \frac{-\frac{g\alpha^2}{w^2} + \beta + \frac{i\gamma(\alpha)}{a}}{\frac{c\alpha^2}{\rho_0 w^2} - \beta - \frac{i\gamma(\alpha)}{a}} = -\frac{g\rho_0}{c} \frac{\gamma(\alpha) - ia\beta \frac{1-a^2}{1+a^2}}{\gamma(\alpha) - ia\beta \frac{2\rho_0 g - (1+a^2)c}{(1+a^2)c}}. \quad (3.11)$$

To solve the Wiener-Hopf problem described by the equation (3.10), it is necessary to factorize the function $K(\alpha)$ as $K(\alpha) = K_+(\alpha)K_-(\alpha)$ where $K_+(\alpha)$ is regular in the half plane $\tau > \tau_-$ and $K_-(\alpha)$ is regular in the half plane $\tau < \tau_+$. For this purpose, the cases $a^2 < 1$ and $a^2 > 1$ are to be considered separately. Here of course a^2 is considered as a real quantity. We note that for $a^2 < 1$, $w < w_0/\sqrt{2} \equiv w_s$. In the case the quantity $2\rho_0g - (1 + a^2)c$ occurring in the denominator in (3.11) is always positive. However, for $a^2 > 1$, $2\rho_0g - (1 + a^2)c$ is positive so long as $w_s < w < w_p$ where

$$w_p^2 = w_s^2 \left(1 - \frac{\sigma w_0^2}{2\rho_0g}\right)^{-1} \quad (3.12)$$

and this is negative when $w > w_p$. These observations are to be kept in mind while factorizing $K(\alpha)$.

(a) $0 < a^2 < 1$

$K(\alpha)$ can be expressed as

$$K(\alpha) = -\frac{g\rho_0}{c} \frac{L(\alpha)}{N(\alpha)},$$

where

$$L(\alpha) = \gamma(\alpha) - ia\beta \frac{1 - a^2}{1 + a^2}, \quad (3.13)$$

and

$$N(\alpha) = \gamma(\alpha) - ia\beta \frac{2g\rho_0 - (1 + a^2)c}{(1 + a^2)c}. \quad (3.14)$$

It is obvious that for the above choice of the branch of $\gamma(\alpha)$, both $L(\alpha)$ and $N(\alpha)$ have no zeros in the strip $\tau_- < \tau < \tau_+$, and these can be factorised as (cf. Noble (1958))

$$L(\alpha) = L_+(\alpha)L_-(\alpha), \quad N(\alpha) = N_+(\alpha)N_-(\alpha), \quad (3.15)$$

where $L_-(\alpha) = L_+(-\alpha)$, $N_-(\alpha) = N_+(-\alpha)$, $|L_+(\alpha)| = O(|\alpha|^{1/2})$ as $|\alpha| \rightarrow \infty$ in $\tau > \tau_-$, $|N_+(\alpha)| = O(|\alpha|^{1/2})$ as $|\alpha| \rightarrow \infty$ in $\tau < \tau_+$, and

$$L_+(\alpha) = \left(-\frac{2ia\beta}{1 + a^2}\right)^{1/2} \times \exp \left[\int_0^\alpha \left(\frac{\xi - \alpha_s}{2} + \frac{1 - a^2}{1 + a^2} \{ \alpha_s \wedge_+ (\alpha_s) - \xi \wedge_+ (\xi) \} \right) \frac{d\xi}{\xi^2 - \alpha_s^2} \right], \quad (3.16)$$

$$N_+(\alpha) = \left(-\frac{2iga\beta\rho_0}{(1 + a^2)c}\right)^{1/2} \exp \left[\int_0^\alpha \left\{ \frac{\xi - \alpha_0}{2} + \frac{2g\rho_0 - (1 + a^2)c}{(1 + a^2)c} \right. \right. \\ \left. \left. \times (\alpha_0 \wedge_+ (\alpha_0) - \xi \wedge_+ (\xi)) \right\} \frac{d\xi}{\xi^2 - \alpha_0^2} \right], \quad (3.17)$$

with

$$\alpha_0^2 = a^2 \beta^2 \left[1 - \left\{ 1 - \frac{2g\rho_0}{(1+a^2)c} \right\}^2 \right], \quad \alpha_s^2 = \frac{4a^4 \beta^2}{(1+a^2)^2}, \quad (3.18)$$

and

$$\Lambda_+(\xi) = \frac{a\beta}{\pi(\xi^2 - a^2\beta^2)^{1/2}} \ln \left\{ \frac{\gamma(\alpha) + \xi - a\beta}{\gamma(\alpha) - \xi + a\beta} \right\}, \quad \Lambda_-(\xi) = \Lambda_+(-\xi). \quad (3.19)$$

Thus

$$\begin{aligned} K_+(\alpha) &= \left(-\frac{g\rho_0}{c} \right)^{1/2} \frac{L_+(\alpha)}{N_+(\alpha)} \\ &= i \frac{\exp \left[\int_0^\alpha \left\{ \frac{\xi - \alpha_s}{2} + \frac{1-a^2}{1+a^2} (\alpha_s \Lambda_+(\alpha_s) - \xi \Lambda_+(\xi)) \right\} \frac{d\xi}{\xi^2 - \alpha_s^2} \right]}{\exp \left[\int_0^\alpha \left\{ \frac{\xi - \alpha_0}{2} + \frac{2g\rho_0 - (1+a^2)c}{(1+a^2)c} (\alpha_0 \Lambda_+(\alpha_0) - \xi \Lambda_+(\xi)) \right\} \frac{d\xi}{\xi^2 - \alpha_0^2} \right]}, \end{aligned} \quad (3.20)$$

and

$$K_-(\alpha) = K_+(-\alpha), \quad |K_+(\alpha)| = O(1) \text{ as } |\alpha| \rightarrow \infty \text{ in } \tau > \tau_-.$$

Now the relation (3.10) is rewritten as

$$\frac{F_+(\alpha)}{K_+(\alpha)} = -K_-(\alpha)G_-(\alpha) + \frac{AK_-(\alpha)}{i(\alpha+k)},$$

which is further rewritten as

$$\frac{F_+(\alpha)}{K_+(\alpha)} - \frac{AK_(-k)}{i(\alpha+k)} = -K_-(\alpha)G_-(\alpha) + \frac{A}{i(\alpha+k)} (K_-(\alpha) - K_(-k)), \quad \tau_- < \tau < \tau_+. \quad (3.21)$$

The left side of (3.21) is analytic in the half plane $\tau > \tau_-$ and the right side is analytic in the half plane $\tau < \tau_+$, and as $|\alpha| \rightarrow \infty$ in the respective half planes, each side is of the order $O(|\alpha|^{-1})$. Applying the principle of analytic continuation and Liouville's theorem, we find that each side of (3.21) vanishes identically. Thus we find the unknown function $F_+(\alpha)$ as given by

$$F_+(\alpha) = \frac{AK_(-k)}{i(\alpha+k)} K_+(\alpha) \quad (3.22)$$

Now the use of (3.7) in (3.8) gives $D(\alpha)$ as

$$D(\alpha) = -\frac{F_+(\alpha)}{\frac{g}{\omega^2} \{\gamma(\alpha) - ia\beta\} L(\alpha)} \quad (3.23)$$

$$= \frac{BK_+(k)}{(\alpha+k) \{\gamma(\alpha) - ia\beta\} L_-(\alpha) N_+(\alpha)}, \quad (3.24)$$

with

$$B = - \left(\frac{\rho_0}{gc} \right)^{1/2} w^2 A.$$

Thus by Fourier inversion, $\phi(x, y)(y < 0)$ is obtained in this case as

$$\phi(x, y) = \frac{BK_+(k)}{2\pi} \int_{\Gamma} \frac{\exp\left(\frac{i\gamma(\alpha)}{a}y - i\alpha x\right)}{(\alpha + k)\{\gamma(\alpha) - ia\beta\}L_-(\alpha)N_+(\alpha)} d\alpha, \quad 0 < w \leq w_s, \quad (3.25)$$

where Γ is a line parallel to the real axis lying in the strip $\tau_- < \tau < \tau_+$.

(b) $a^2 > 1$ ($w > w_s$)

For the choice of the branch of $\gamma(\alpha)$ made here, the function $L(\alpha)$ has zeros at $\alpha = \pm\alpha_s$ for $a^2 > 1$ where α_s is defined in (3.18) while the function $N(\alpha)$ has zeros at $\alpha = \pm\alpha_0$, α_0 being defined also in (3.18), only when

$$(1 + a^2)c > 2g\rho_0,$$

i.e., only when $w > w_p$, where

$$w_p^2 = w_s^2 \left(1 - \frac{\sigma w_0^2}{2g\rho_0} \right)^{-1} \quad (3.26)$$

Thus it follows that for $a^2 > 1$, two situations arise according as $w < w_p$ and $w > w_p$. These are also dealt with separately.

(i) $w_s < w < w_p$

In this case $L(\alpha)$ has zeros at $\alpha = \pm\alpha_s$ while $N(\alpha)$ does not have any zero in the strip $\tau_- < \tau < \tau_+$ for the aforesaid choice of the branch of $\gamma(\alpha)$. We write $K(\alpha)$ in this case as

$$K(\alpha) = -\frac{g\rho_0}{c} \frac{\alpha^2 - \alpha_s^2}{M(\alpha)N(\alpha)}, \quad (3.27)$$

where

$$M(\alpha) = \gamma(\alpha) - ia\beta \frac{a^2 - 1}{a^2 + 1}, \quad (3.28)$$

We note that $M(\alpha)$ is analytic in the strip $\tau_- < \tau < \tau_+$ and can be factorized as

$$M(\alpha) = M_+(\alpha)M_-(\alpha),$$

where

$$M_+(\alpha) = \left(-\frac{2ia^3\beta}{1+a^2} \right)^{1/2} \exp \left[\int_0^\alpha \left(\frac{\xi - \alpha_s}{2} + \frac{a^2 - 1}{a^2 + 1} \{ \alpha_s \wedge_+ (\alpha_s) - \xi \wedge_+ (\xi) \} \right) \frac{d\xi}{\xi^2 - \alpha_s^2} \right], \quad (3.29)$$

$$M_-(\alpha) = M_+(-\alpha), \quad |M_{\pm}(\alpha)| = O(|\alpha|^{1/2})$$

as $|\alpha| \rightarrow \infty$ in $\tau \leq \tau_{\mp}$, $M_{\pm}(\alpha)$ is analytic in the half-plane $\tau \geq \tau_{\mp}$. Finally, $K_+(\alpha)$ in this case is obtained as

$$\begin{aligned} K_+(\alpha) = & -\frac{(1+a^2)(\alpha+\alpha_0)}{2a^2\beta} \\ & \exp \left[-\int_0^\alpha \left\{ \frac{\xi-\alpha_0}{2} + \frac{2g\rho_0 - (1+a^2)c}{(1+a^2)c} (\alpha_0 \wedge_+ (\alpha_0) - \xi \wedge_+ (\xi)) \right\} \right. \\ & \left. \times \frac{d\xi}{\xi^2 - \alpha_0^2} - \int_0^\alpha \left\{ \frac{\xi-\alpha_s}{2} + \frac{a^2-1}{a^2+1} (\alpha_s \wedge_+ (\alpha_s) - \xi \wedge_+ (\xi)) \right\} \frac{d\xi}{\xi^2 - \alpha_s^2} \right]. \end{aligned} \quad (3.30)$$

$\phi(x, y)$ in this case is found to be

$$\phi(x, y) = \frac{BK_+(k)}{2\pi} \int_{\Gamma} \frac{M_-(\alpha) \exp \left(\frac{i\gamma(\alpha)}{a} y - i\alpha x \right)}{(\alpha+k)(\alpha-\alpha_s) \{ \gamma(\alpha) - ia\beta \} N_+(\alpha)} d\alpha, \quad w_s < w \leq w_p, \quad (3.31)$$

where Γ is the same contour as in (3.25).

(ii) $w_p < w < w_0$

In this case $L(\alpha)$ has zeros at $\alpha = \pm\alpha_s$ and $N(\alpha)$ has zeros at $\alpha = \pm\alpha_0$ in the strip $\tau_- < \tau < \tau_+$, so that $K(\alpha)$ can be written as

$$K(\alpha) = -\frac{g\rho_0}{c} \frac{(\alpha^2 - \alpha_s^2)}{(\alpha^2 - \alpha_0^2)} \frac{P(\alpha)}{M(\alpha)}, \quad (3.32)$$

where

$$P(\alpha) = \gamma(\alpha) - ia\beta \frac{(1+a^2)c - 2g\rho_0}{(1+a^2)c}, \quad (3.33)$$

which is analytic in the strip $\tau_- < \tau < \tau_+$. $P(\alpha)$ can be factorized as

$$P(\alpha) = P_+(\alpha)P_-(\alpha),$$

where

$$\begin{aligned} P_+(\alpha) = & \left\{ -2ia\beta \left(1 - \frac{g\rho_0}{(1+a^2)c} \right) \right\}^{1/2} \exp \left[\int_0^\alpha \left\{ \frac{\xi-\alpha_0}{2} \right. \right. \\ & \left. \left. + \frac{(1+a^2)c - 2g\rho_0}{(1+a^2)c} (\alpha_0 \wedge_+ (\alpha_0) - \xi \wedge_+ (\xi)) \right\} \frac{d\xi}{\xi^2 - \alpha_0^2} \right], \end{aligned} \quad (3.34)$$

and $P_-(\alpha) = P_+(-\alpha)$, $|P_{\pm}(\alpha)| = O(|\alpha|^{1/2})$ as $|\alpha| \rightarrow \infty$ in $\tau \geq \tau_{\mp}$, $P_+(\alpha)$ is analytic for $\tau > \tau_-$ while $P_-(\alpha)$ is analytic for $\tau < \tau_+$. Thus, we find that in this case

$$K_+(\alpha) = i \sqrt{\frac{g\rho_0}{c} \frac{\sqrt{1+a^2}}{a}} \left(1 - \frac{g\rho_0}{(1+a^2)c}\right)^{1/2} \frac{\alpha + \alpha_s}{\alpha + \alpha_0} \times \frac{\exp \left[\int_0^\alpha \left\{ \frac{\xi - \alpha_0}{2} + \frac{(1+a^2)c - 2g\rho_0}{(1+a^2)c} (\alpha_0 \wedge_+ (\alpha_0) - \xi \wedge_+ (\xi)) \right\} \frac{d\xi}{\xi^2 - \alpha_0^2} \right]}{\exp \left[\int_0^\alpha \left\{ \frac{\xi - \alpha_s}{2} + \frac{a^2 - 1}{a^2 + 1} (\alpha_s \wedge_+ (\alpha_s) - \xi \wedge_+ (\xi)) \right\} \frac{d\xi}{\xi^2 - \alpha_s^2} \right]}. \quad (3.35)$$

Finally, $\phi(x, y)$ in this case is obtained as

$$\phi(x, y) = \frac{BK_+(k)}{2\pi} \int_{\Gamma} \frac{P_+(\alpha)M_-(\alpha) \exp \left(\frac{i\gamma(\alpha)}{a} y - i\alpha x \right)}{(\alpha + k)(\alpha - \alpha_s)(\alpha + \alpha_0)\{\gamma(\alpha) - ia\beta\}} d\alpha, \quad w_p < w < w_0, \quad (3.36)$$

where Γ is the same contour mentioned earlier.

Now by passing on to the limit as $\varepsilon \rightarrow +0$ in the results (3.25), (3.31) and (3.36), we obtain the final result in the compact form

$$\phi(x, y) = \frac{BK_+(k)}{2\pi} \int_{-\infty}^{\infty} \frac{\Omega_1(\alpha) \exp \left(\frac{i\gamma(\alpha)}{a} y - i\alpha x \right)}{(\alpha + k)\{\gamma(\alpha) - ia\beta\}\Omega_2(\alpha)} d\alpha, \quad (3.37)$$

where

$$\Omega_1(\alpha) = \begin{cases} 1, & 0 < w \leq w_s, \\ M_-(\alpha), & w_s < w \leq w_p, \\ P_+(\alpha)M_-(\alpha), & w_p < w < w_0, \end{cases} \quad (3.38)$$

$$\Omega_2(\alpha) = \begin{cases} L_-(\alpha)N_+(\alpha), & 0 < w \leq w_s, \\ (\alpha - \alpha_s)N_+(\alpha), & w_s < w \leq w_p, \\ (\alpha - \alpha_s)(\alpha + \alpha_0), & w_p < w < w_0, \end{cases} \quad (3.39)$$

and $K_+(k)$ having appropriate values in the different ranges of w . The integration in (3.37) is taken along the real axis of the α -plane with indentation above the negative poles and below the positive poles. In the next section we analyse the solutions (3.37) asymptotically.

4. Asymptotic Analysis of the Solutions. For asymptotic analysis of the integral in (3.37), we introduce the polar co-ordinates (r, θ) defined by $x = r \cos \theta$, $y = -r \sin \theta$, $0 \leq \theta \leq \pi$, where θ is measured in a clockwise sense from the x -axis. We note that the characteristic equations of the PDE (2.9) represent a pair of straight lines $y = \pm ax$ passing through the origin and form a characteristic cone. These straight lines are inclined at angles θ_c and $\pi - \theta_c$ with the x -axis where θ_c is defined by $\tan \theta_c = a$. Let θ_0 be defined by $\tan \theta_0 = \frac{a^2 b}{k}$, then θ_0 is the angle which the group velocity vector of the incident wave field ϕ_0 makes with the x -axis.

From the representation (3.37) it follows that $\phi(x, y)$ is continuous in the region $y \leq 0$ together with its gradient, but the second order derivatives are logarithmically divergent everywhere on the boundaries of the characteristic cone given by the lines $\theta = \theta_c$, $\theta = \pi - \theta_c$ which pass through the origin. This means that the logarithmic singularity of the second order derivatives of the diffracted fields on the edge of the inertial surface propagates along the characteristics of the governing PDE.

Asymptotic estimates of the integral in the representations (3.37) in different regions are obtained by the method of steepest descent. The final result for the total wave field u is obtained in the following form

$$u = \phi_0 + \begin{cases} \phi_2 + \phi_d^{(1)} + \phi_{IS}, & 0 \leq \theta < \theta_0, \\ \phi_1 + \phi_d^{(1)} + \phi_{IS}, & \theta_0 < \theta < \theta_c, \\ \phi_1 + \phi_d^{(2)}, & \theta_c < \theta < \pi - \theta_c, \\ \phi_1 + \phi_d^{(1)} + \phi_s, & \pi - \theta_c < \theta \leq \pi, \end{cases} \quad (4.1)$$

where ϕ_1 is given by (2.7),

$$\phi_2 = -\frac{ck^2 + \rho_0 w^2(ib - \beta)}{ck^2 - \rho_0 w^2(ib + \beta)} \exp(i by + ikx),$$

$$\phi_{IS} = \frac{iBK_+(k)\Omega_1(-\alpha_0)}{(k - \alpha_0)\{\gamma(\alpha_0) - ia\beta\}\Omega_2'(-\alpha_0)} \exp\left(\frac{\beta\{(1+a^2)c - 2g\rho_0\}}{(1+a^2)c}y + i\alpha_0 x\right),$$

$$\phi_s = \frac{iBK_+(k)\Omega_1(\alpha_s)}{(k + \alpha_s)\{\gamma(\alpha_s) - ia\beta\}\Omega_2'(\alpha_s)} \exp\left(\frac{\beta}{a^2 + 1}\{(a^2 - 1)y - 2ia^2 x\}\right),$$

$$\begin{aligned} \phi_d^{(1)} &= \frac{BK_+(k)\Omega_1(\alpha_*^{(1)})}{(k + \alpha_*^{(1)})\{\gamma(\alpha_*^{(1)}) - ia\beta\}\Omega_2(\alpha_*^{(1)})} \frac{1}{\{2\pi\beta r P(\theta)\}^{1/2}} \\ &\quad \times \frac{a\beta \sin \theta}{P(\theta)} \exp\left(i\left\{\beta r P(\theta) + \frac{\pi}{4}\right\}\left[1 + O\left(\frac{1}{\beta r}\right)\right]\right), \end{aligned}$$

$$\begin{aligned} \phi_d^{(2)} &= \frac{iBK_+(k)\Omega_1(\alpha_*^{(2)})}{(k + \alpha_*^{(2)})\{\gamma(\alpha_*^{(2)}) - ia\beta\}\Omega_2(\alpha_*^{(2)})} \frac{1}{\{2\pi\beta r Q(\theta)\}^{1/2}} \\ &\quad \times \frac{a\beta \sin \theta}{Q(\theta)} \exp\left(-\beta r Q(\theta)\left[1 + O\left(\frac{1}{\beta r}\right)\right]\right), \end{aligned}$$

with

$$P(\theta) = (a^2 \cos^2 \theta - \sin^2 \theta)^{1/2}, \quad 0 < \theta < \theta_c, \quad \pi - \theta_c < \theta < \pi,$$

$$Q(\theta) = (\sin^2 \theta - a^2 \cos^2 \theta)^{1/2}, \quad \theta_c < \theta < \pi - \theta_c,$$

$$\alpha_*^{(1)} = -\frac{a^2 \beta \cos \theta}{P(\theta)}, \quad \alpha_*^{(2)} = \frac{ia^2 \beta \cos \theta}{Q(\theta)}.$$

In (4.1), ϕ_0 is the incident internal wave field, ϕ_1 is the wave reflected from the free surface, ϕ_2 is the wave reflected from the inertial interface, ϕ_{IS} is the wave due to inertial surface, which exists only when $w_p < w < w_0$, ϕ_S is the surface wave which exists when $w_s < w < w_0$, and $\phi_d^{(1)}$, $\phi_d^{(2)}$ are contributions due to diffraction. This asymptotic analysis is consistent with a similar analysis by Gabov and Sveshnikov (1982) and Varlamov (1985) in connection with their studies on internal wave scattering by the edge of an ice field and an elastic plate in the form of a half space respectively.

5. Discussion. The terms ϕ_0, ϕ_1, ϕ_2 represent the zeroth order approximation terms in the representation (4.1) of the total wave field in the sense that they occur according to the laws of geometrical optics and without considering diffraction by the inertial surface. This becomes obvious when the area density σ of the inertial surface is made equal to zero. In that case, $\phi_2 = \phi_1$ and $\phi_d^{(1)}, \phi_d^{(2)}, \phi_{IS}$ and ϕ_S vanish identically as expected since no diffraction can occur in the absence of the inertial surface.

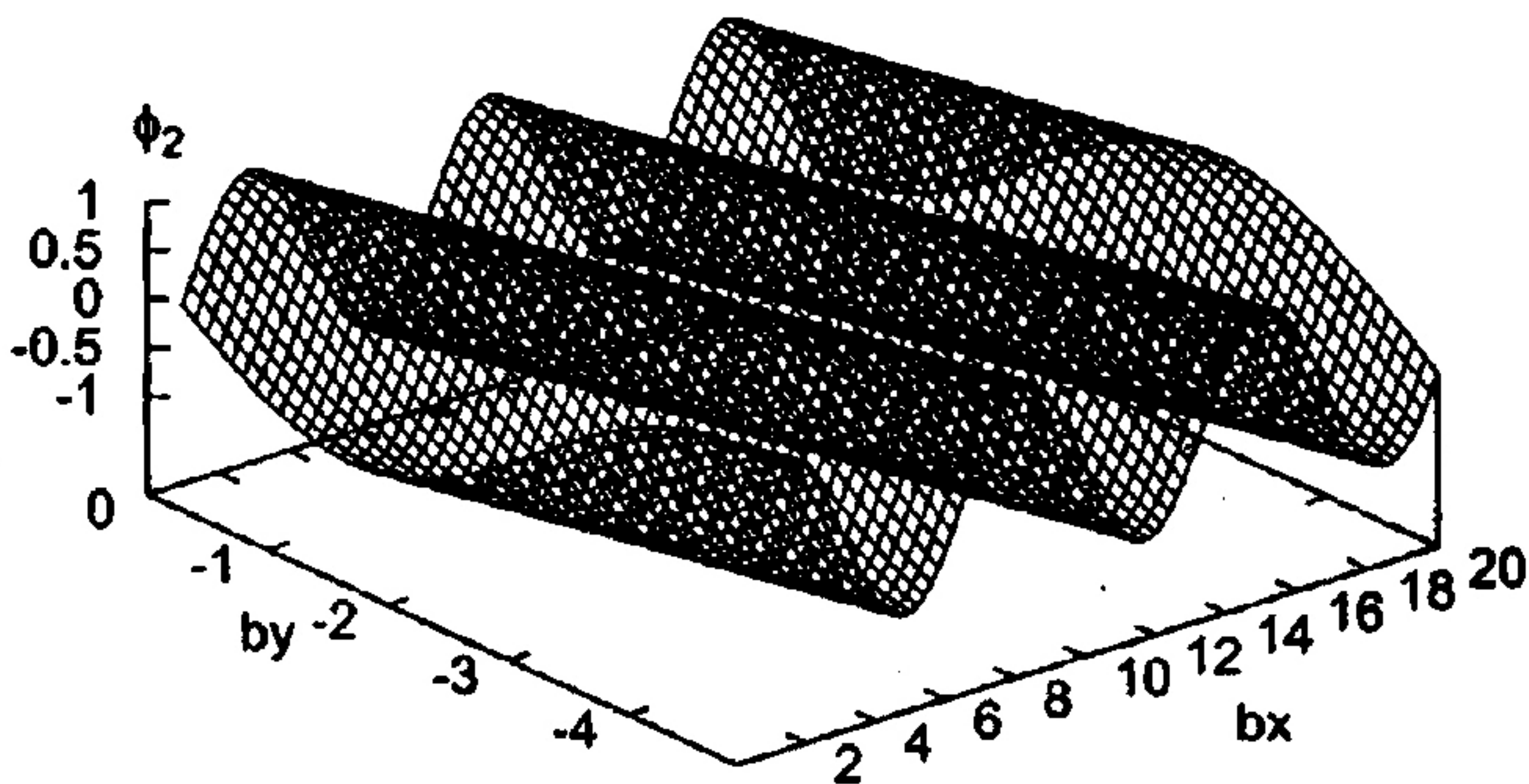

Fig. 1. Waves reflected from the inertial surface

$$\left(\frac{gb}{\omega^2} = 5.0, \frac{\omega_0}{\omega} = 1.5, \frac{g\rho_0}{c} = 1.01, \frac{\sigma\omega^2}{c} = .01 \right)$$

In fig. 1, ϕ_2 i.e., the wave reflected from the inertial surface, is plotted against bx and by for $\frac{gb}{\omega^2} = 5.0$, $\frac{\omega_0}{\omega} = 1.5$, $\frac{g\rho_0}{c} = 1.01$. It is observed that these waves propagate in the region under the inertial surface without any decay of its amplitude.

The terms ϕ_d^1 and ϕ_d^2 are due to scattering. ϕ_d^1 arises when $0 < \theta < \theta_c$ and $\pi - \theta_c < \theta < \pi$ i.e., in the region within the characteristic cone. Fig. 2 depicts ϕ_d^1 in the region $0 < \theta < \theta_c$ against br and fig. 3 depicts ϕ_d^1 in the region $\pi - \theta_c < \theta < \pi$ against br for $\frac{gb}{\omega^2} = 5.0$, $\frac{\omega_0}{\omega} = 1.5$, $\frac{g\rho_0}{c} = 1.01$, $\frac{\sigma\omega^2}{c} = 0.01$. From these figures it is observed that the diffracted waves in the region $0 < \theta < \theta_c$ decays faster than those in the region $\pi - \theta_c < \theta < \pi$ far away from the edge of the inertial surface.

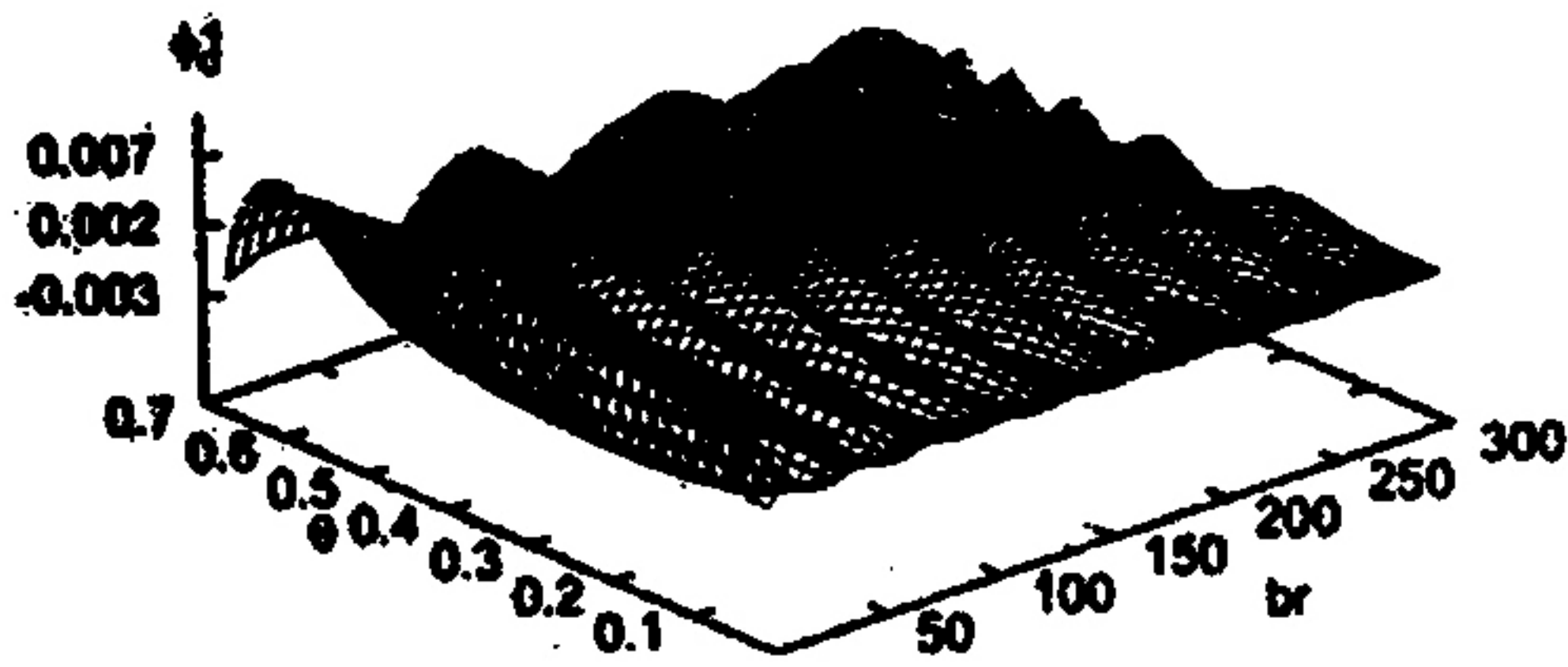

Fig. 2. Waves due to diffraction
in $0 < \theta < \theta_c$

$$\left(\frac{gb}{\omega^2} = 5.0, \frac{\omega_0}{\omega} = 1.5, \right. \\ \left. \frac{g\rho_0}{c} = 1.01, \frac{\sigma\omega^2}{c} = .01 \right)$$

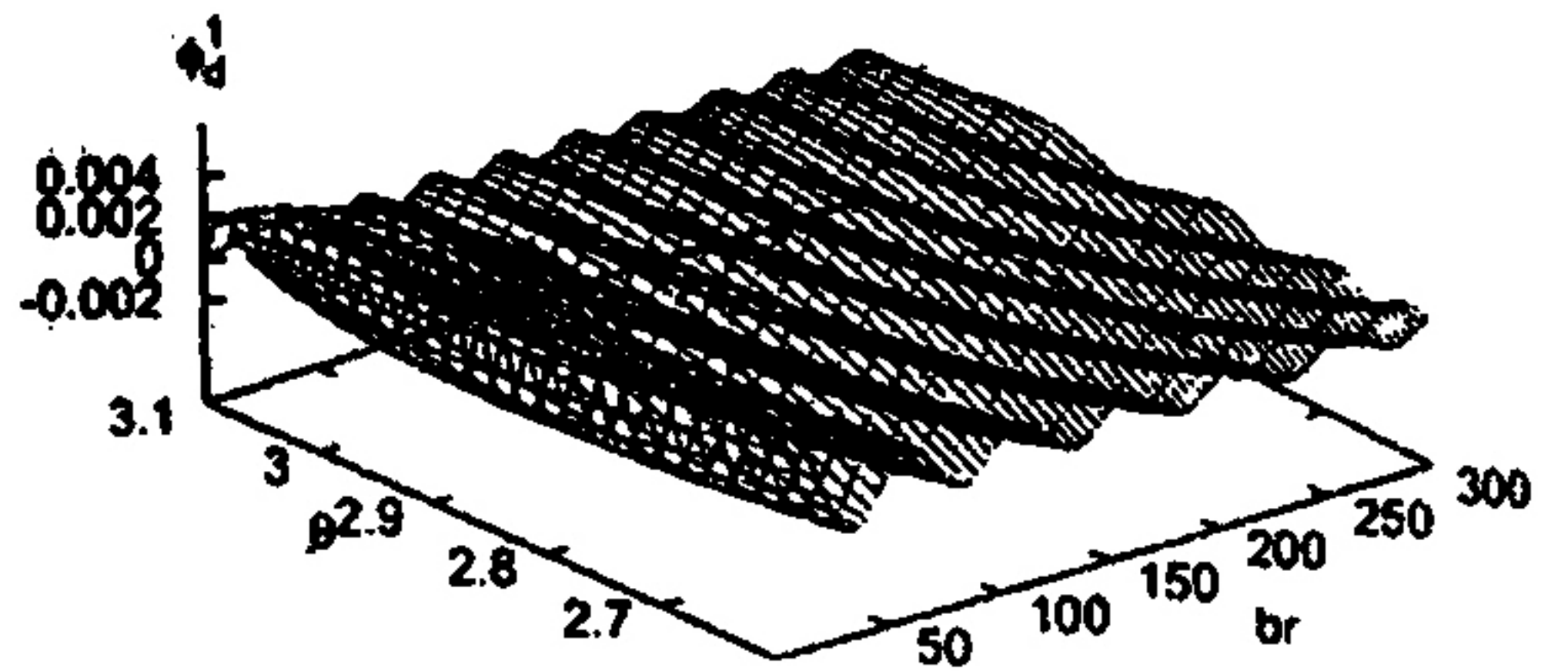

Fig. 3. Waves due to diffraction
in $\pi - \theta_c < \theta < \pi$

$$\left(\frac{gb}{\omega^2} = 5.0, \frac{\omega_0}{\omega} = 1.5, \right. \\ \left. \frac{g\rho_0}{c} = 1.01, \frac{\sigma\omega^2}{c} = .01 \right)$$

The term ϕ_d^2 arises in the region $\theta_c < \theta < \pi - \theta_c$, i.e., in the region outside the characteristic cone. In fig. 4, ϕ_d^2 is plotted against br for $\frac{gb}{\omega^2} = 5.0$, $\frac{\omega_0}{\omega} = 1.3$, $\frac{g\rho_0}{c} = 1.01$, $\frac{\sigma\omega^2}{c} = 0.01$. We observe from this figure that ϕ_d^2 has no wave like character and it decays exponentially far away from the edge of the inertial surface.

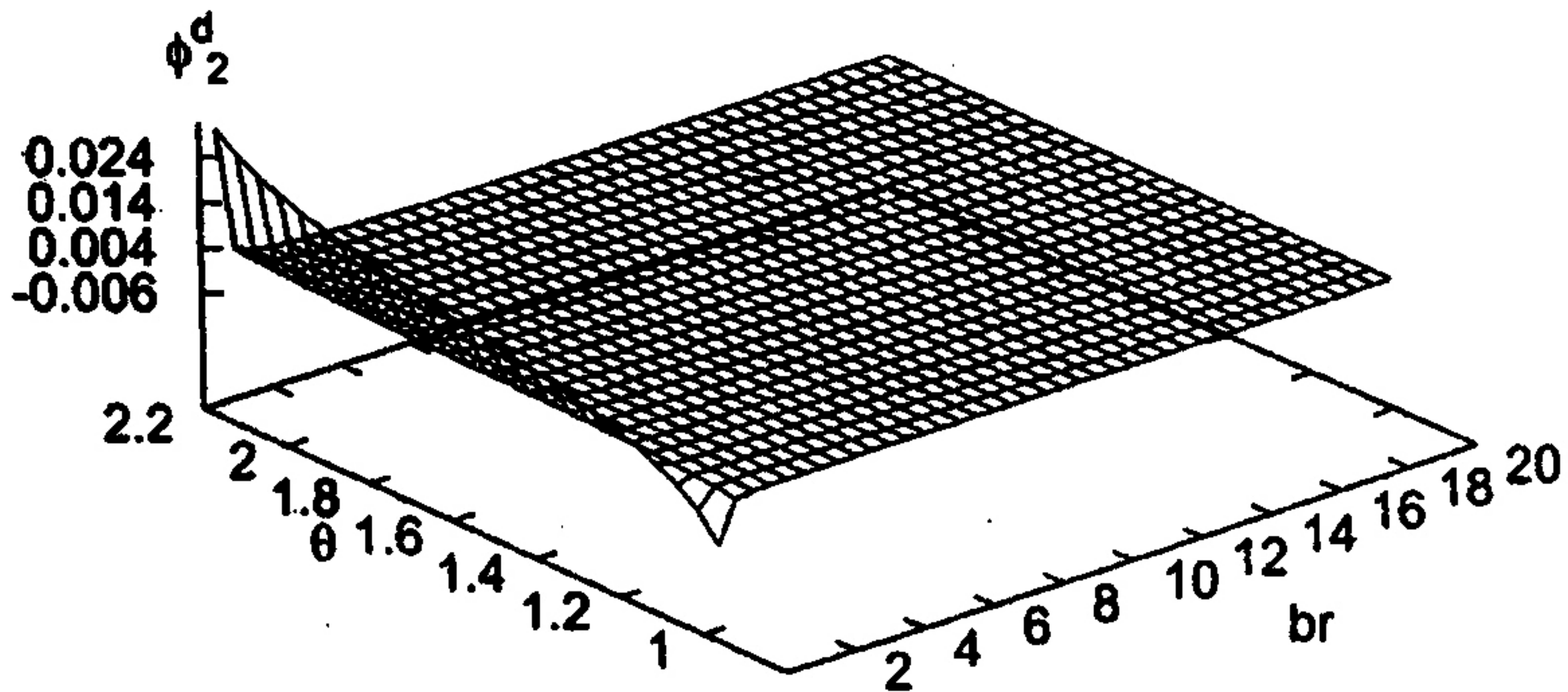

Fig. 4. Waves due to diffraction in $\theta_c < \theta < \pi - \theta_c$

$$\left(\frac{gb}{\omega^2} = 5.0, \frac{\omega_0}{\omega} = 1.3, \frac{g\rho_0}{c} = 1.01, \frac{\sigma\omega^2}{c} = .01 \right)$$

The term ϕ_s exists when $\omega_s < \omega < \omega_0$ and arises in the region $\pi - \theta_c < \theta < \pi$. Fig. 5 depicts ϕ_s against bx and by for $\frac{gb}{\omega^2} = 5.0$, $\frac{\omega_0}{\omega} = 1.3$, $\frac{g\rho_0}{c} = 1.01$, $\frac{\sigma\omega^2}{c} = 0.01$. It is observed from this figure that the waves propagate under the free surface along the negative x direction without any decay of its amplitude and decays exponentially with the depth of the liquid.

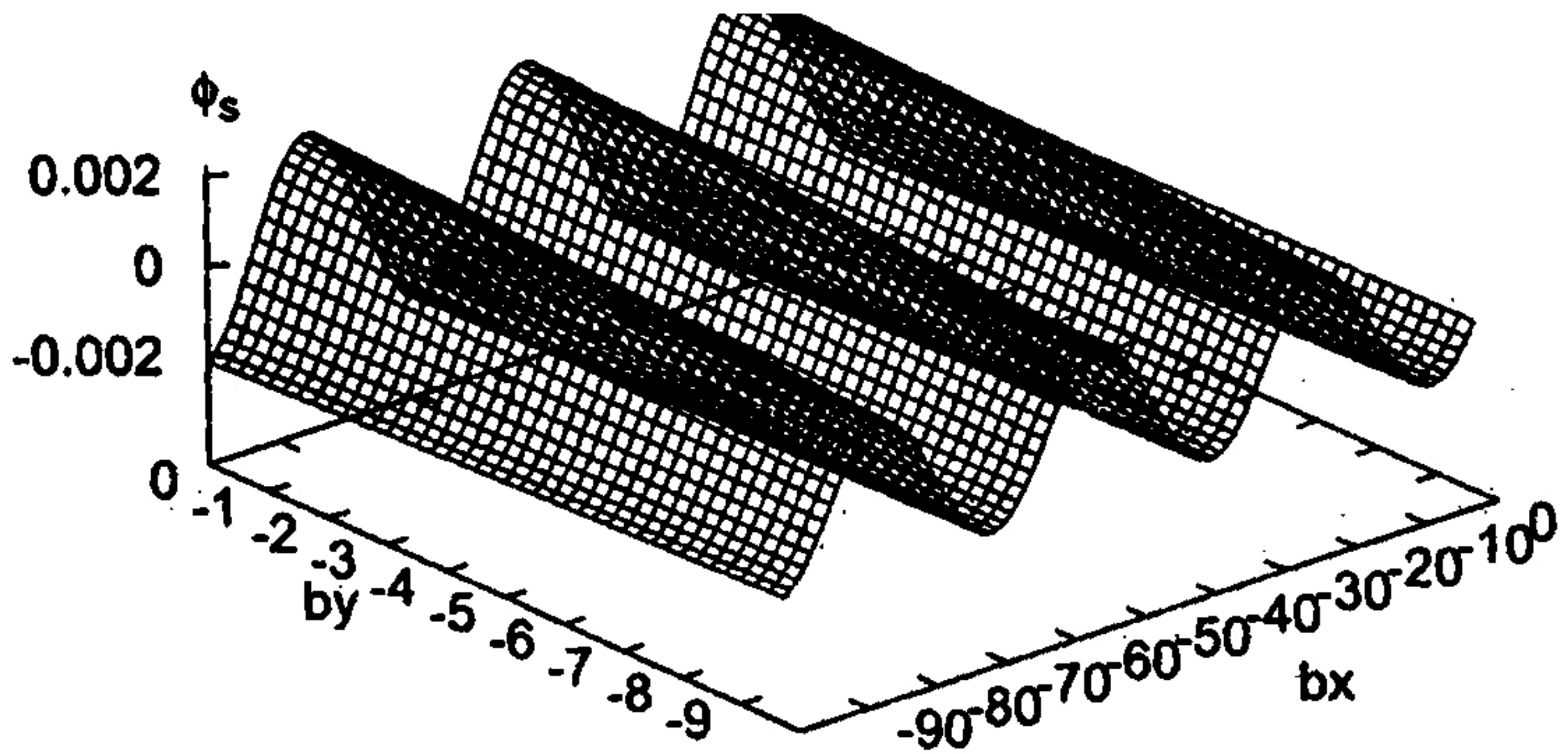

Fig. 5. Waves under the free surface in $\pi - \theta_c < \theta < \pi$

$$\left(\frac{gb}{\omega^2} = 5.0, \frac{\omega_0}{\omega} = 1.3, \frac{g\rho_0}{c} = 1.01, \frac{\sigma\omega^2}{c} = .01 \right)$$

Finally, the term ϕ_{IS} exists when $\omega_p < \omega < \omega_0$ and arises in the region $0 < \theta < \theta_c$. In Fig. 6, ϕ_{IS} is plotted against bx and by for $\frac{gb}{\omega^2} = 5.0$, $\frac{\omega_0}{\omega} = 1.3$, $\frac{g\rho_0}{c} = 1.01$, $\frac{\sigma\omega^2}{c} = 0.01$. It is observed that the waves propagate under the inertial surface along the positive x -direction without any decay of its amplitude and decays exponentially with the depth of the liquid.

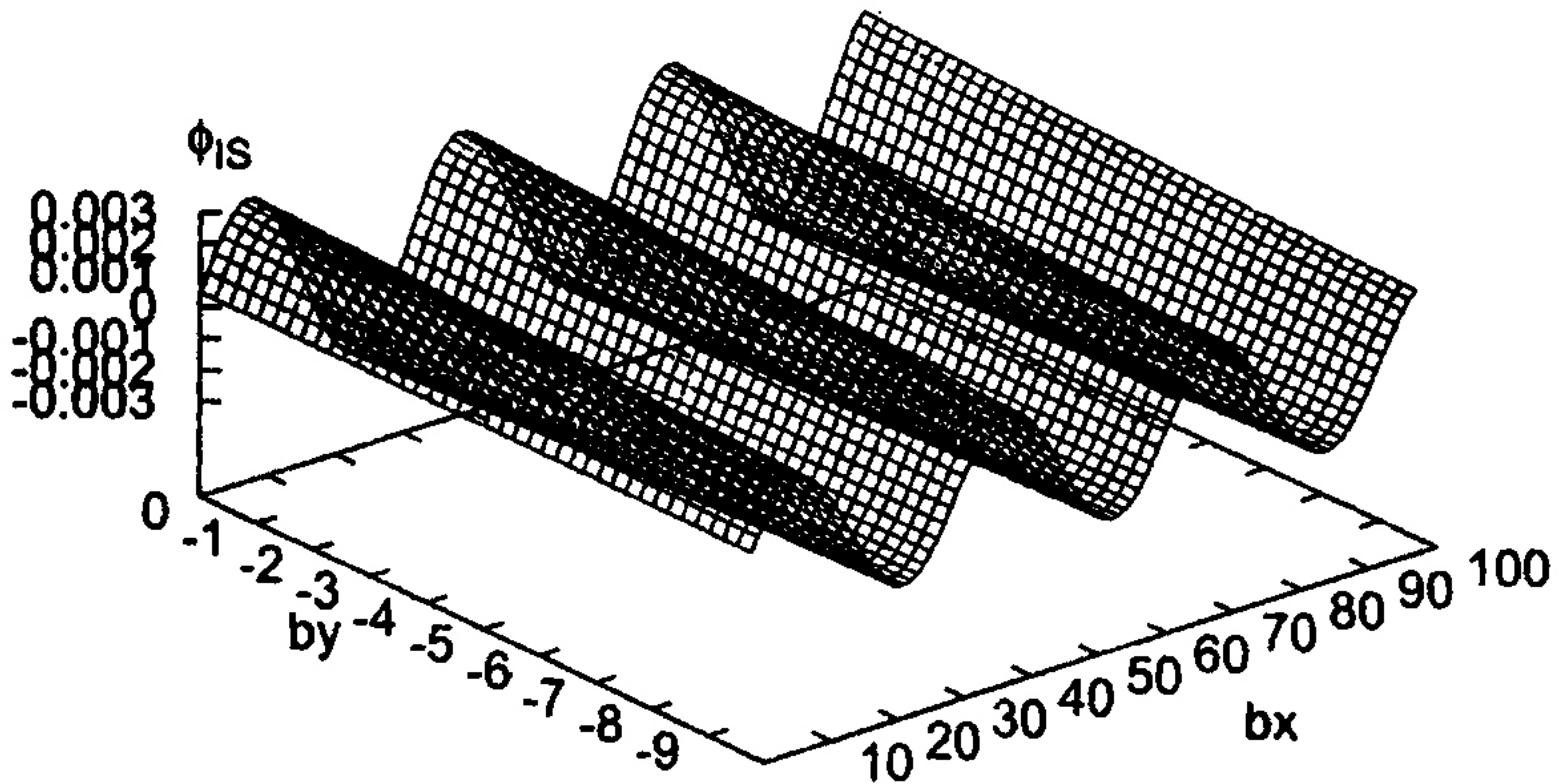

Fig. 6. Waves under the inertial surface in $0 < \theta < \theta_c$

$$\left(\frac{gb}{\omega^2} = 5.0, \frac{\omega_0}{\omega} = 1.3, \frac{g\rho_0}{c} = 1.01, \frac{\sigma\omega^2}{c} = .01 \right)$$

From figs. 5 and 6, we also observe that the wave generated due to the presence of the inertial surface is at higher frequencies than the wave generated on the free surface of the liquid.

References

- Gabov, S.A., Sveshnikov, A.G. and Shatov, A.K. (1989) : Dispersion of internal waves by an obstacle floating on the boundary separation liquids, *PMM*, 53, 727.
- Gabov, S.A. (1982) : Diffraction at a half-plane of internal waves described by the Klein-Gordon equation, *Sov. Phys. Dokl.*, 27, 394.
- Gabov, S.A. and Sveshnikov, A.G. (1982) : On the diffraction of internal waves by the edge of an ice field, *Soviet Math. Dokl.*, 26, 8.
- Kamoria, M., Mandal, B.N. and Chakrabarti, A. (1999) : The Wiener-Hopf solution of a class of mixed boundary value problems arising in surface wave phenomena, *Wave Motion*, 29, 267.
- Noble, B. (1958) : *Methods Based on the Wiener-Hopf Technique for the Solution of Partial Differential Equations*, Pergamon Press, New York.
- Peters, A.S. (1950) : The effect of a floating mat on water waves, *Comm. Pure Appl. Math.*, 3, 319.
- Varlamov, V.V. (1983) : Diffraction of internal waves in a stratified liquid at semi-infinite wall, *U.S.S.R. Comput. Maths. Phys.*, 23, 87.
- (1985) : The Scattering of internal waves by the periphery of an elastic plate, *U.S.S.R. Comput. Maths. Phys.*, 25, 58.
- Watts, M. and Keller, J.B. (1950) : Reflection of water waves from floating ice in water of finite depth, *Comm. Pure Appl. Math.*, 3, 305.

¹DEPARTMENT OF MATHEMATICS
PRASANNADEB WOMEN'S COLLEGE
JALPAIGURI 735101
WEST BENGAL
INDIA

²PHYSICS AND APPLIED MATHEMATICS UNIT
INDIAN STATISTICAL INSTITUTE
208 B.T. ROAD
KOLKATA 700108
INDIA
E-MAIL : biren@isical.ac.in